



MEDIA



MILITARY



HEALTHCARE



AI BACKUP



FORENSICS



DATA CENTERS

- ▶ **High-Performance**
- ▶ **Ultimate Protection**
- ▶ **Portable & Durable**
- ▶ **Immense Storage**
- ▶ **Solutions for Mission-Critical Applications**



CIPHERTEX[®] data security

Developed and
Manufactured in the USA



All SecureNas[®] storage
units include a proprietary
operating system



Lightning fast networking
speed and file transfers



Exclusive paired Encryption Key for
SecureNAS[®] access



Protect against unauthorized cryptographic
access with FIPS 140-2 Level 3 Security



Federal requirements for a
quality management system



GSA Contract No.
GS35-487DA





U.S. AIR FORCE



Offers affordable, customizable solutions using hyper-fast and tamper-proof encryption. All our products are made in the United States. We rise above our competitors by offering:

- Hardware encryption key FIPS-140-2 Level 3 Certified
- Rugged design certified in a military environmental test lab.
- Powerful system and large capacity with a minimal footprint
- Metal door with a lock to prevent theft and data loss by accidental human error theft/contact
- Pre-installed software including operating system without yearly licensing fee (No maintenance)
- (2) Complimentary 1G copper and (2) 10G fiber ports
- RSYNC enabled
- Instant Secure Erase (ISE)
- Block USB access to SecureNAS®

MISSION STATEMENT

At Ciphertex Data Security, we aim to provide unparalleled data protection and secure digital solutions that empower individuals, businesses, and organizations to thrive in a rapidly evolving digital landscape. We are dedicated to delivering cutting-edge technologies, robust encryption, and comprehensive cybersecurity measures that safeguard sensitive information from malicious threats. Our commitment to excellence drives us to stay at the forefront of data security, constantly researching, innovating, and adapting to emerging threats. We strive to build trust and confidence in our customers by offering reliable, scalable, and user-friendly solutions that ensure their data's confidentiality, integrity, and availability. With a relentless focus on customer satisfaction, we aim to be the trusted partner that enables organizations to navigate the complexities of the digital world, fortifying their defenses and ensuring a secure and prosperous future.



OPERATING SYSTEM

SECURITY

PERFORMANCE

EFFICIENCY

BACKUP



Seamless Networking Intelligent Storage

SecureNAS® Software is designed to reduce the complexity of data security with FIPS 140-2 Level 3 validated cryptographic modules. OpenZFS, automated backup, and migration come installed on every SecureNAS®, making sharing data between many connected devices a breeze.

Cutting-Edge Security Features for Maximum Protection

In an era of escalating security threats, protecting your critical data is paramount. At Ciphertex Data Security, we take security seriously. Our modern architecture is crafted to withstand today's sophisticated attacks, ensuring robust defense for your sensitive information. By leveraging our innovative approach, you can safeguard your data, minimize downtime, and optimize resource utilization. Additionally, we offer a comprehensive suite of security features that seamlessly integrate with software and systems from industry ecosystem partners.

CAPABLE

- A simplified approach to sharing files between collaborators on your network
- Provides a scalable solution built for the unique requirements of your business
- We partner with you every step to optimize your system and save you time and money
- Comes installed on every SecureNAS® appliance and costs \$0
- A light web GUI frees up memory for other important data serving tasks

IT Management for All Environments

Manage Ciphertex SecureNAS® servers in local and remote environments.

Accomplish More with Intelligent Storage

With automated redundancy and backup tools integrated across the SecureNAS solutions portfolio, your systems work for you.

Performance

Delivers exceptional performance across a wide spectrum of assignments. Produces faster results to elevate your business productivity.

Cybersecurity at the Edge

Ciphertex-developed security packages enhance your network's safety and speed.

Ciphertex Protect® Key

FIPS 140-2 Level 3 certified Ciphertex Protect hardware encryption keys can be paired and managed within the storage management platform.

Optimize With Deduplication

A highly optimized version of block-based data deduplication reduces storage space consumption while improving read/write speeds.

Cross-environment connectivity

Has wide-ranging compatibility, supporting FTP, iSCSI, NFS, SMB, WebDAV, and Rsync

Ultimate expansion option

Modern IT infrastructures are powerful and adaptable, yet, often challenging to manage. Ciphertex SecureNAS Series and Ciphertex OS help reduce the complexity of your IT infrastructure with intuitive tools that work together to deliver automated, repeatable processes, enabling simple management.

Instant Secure Erase Enabled

Instant secure erase (ISE) encrypts the drive, and when it is time to permanently delete all the data, only the encryption key has to be deleted. This method deletes the drive in a few seconds.

Software and solutions to meet your business's requirements

In addition to the native intelligence of Linux and ZFS, Ciphertex-developed security and performance packages are implemented to optimize file sharing, data integrity, volume encryption, and scalability. RhinOS 24.1 also features resilient RAIDZ, backup restoration, and synchronization tools to ensure the preservation of your data and complete BCDR readiness.

Scale out with speed

ZFS integration offers petabyte scalability at a reduced cost. Connect another Ciphertex storage device and configure it via the primary controller interface.

Cost-effective

The SecureNAS® portfolio allows you to tailor, deploy, and manage your infrastructure while lowering operating costs. Futureproof your office or data center with expandable compute-ready network storage.

Efficient data management

From the convenience of a lightweight web interface, users can configure ZFS storage pools.

OpenZFS for a safer, more resilient system.

Highly flexible storage pool and volume configuration options include growing/re-layout for ZFS-based pools, thin provisioning/over-provisioning for storage volumes, and volume resizing. Compression can be enabled for storage volumes, increasing usable capacity and performance by reducing the amount of stored data.





Military Applications

We Develop Innovative Ultra-High Capacity **SSD Technology to Maximize Power Efficiency and Improve Performance, Security, and Reliability.**

CIPHERTEX® developed the SecureNAS® to Combat Cyber Threats with Unrivaled Performance & Supreme Security.

Introducing the portable SecureNAS® High-Performance, All-Flash Encrypted Storage. Experience the power and Security and the Efficiency of the SecureNAS® line, a cutting-edge solution for your enterprise storage needs. With a massive storage capacity of up to 480TB, this ruggedized portable system ensures your data is protected and easily accessible wherever you go. It's time to take your data security to the next level with:

TAMPER-PROOF HARDWARE ENCRYPTION

Tamper-proof hardware encryption key Ciphertex Protect® FIPS 140-2 level 3 certified and Linux ZFS Resiliency. Your data remains protected from unauthorized access, and our rugged mechanical design ensures durability in any environment. The metal door with lock adds an extra layer of physical security, while the blocked USB access to SecureNAS® prevents any potential security breaches.

UNPARALLELED PERFORMANCE AND RELIABILITY

Featuring hot-swappable SSDs and two mirrored internal SSDs for OS hosting. The SecureNAS® is powered by an Intel® Xeon® D (4, 8, or 16 Core) processor, delivering high-capacity storage without compromising speed. With DDR4 memory options ranging from 32GB to 1256GB, you can expect optimal high performance for your critical tasks. The built-in Intel® AES-NI ensures robust security and reduced latency for a wide range of cryptographic applications, providing peace of mind for your sensitive data.

ENHANCED SECURITY AND FLEXIBILITY

Experience the best-in-class security and flexibility with our complimentary RhinOS 24.1 (OS) Software Linux ZFS enterprise. This advanced operating system empowers fast data access, backup/restoration, file server, and virtualization applications while maintaining top-notch security standards. The SecureNAS® optimizes your IT infrastructure, with two PCIe expansion slots supporting multiple network interface cards, enabling seamless communication across different networks, PCIe devices, SSDs, and graphic cards.

COMPLETE BUSINESS-READY SOLUTION

Our SecureNAS® is more than just storage; it's a complete business-ready solution. You can streamline your operations and ensure smooth data management with cross-platform file sharing, comprehensive backup and disaster recovery, iSCSI, virtualization, and other business applications. Supports Rsync iSCSI, virtual machine hosting, and ZFS RAIDZ resiliency, guaranteeing data integrity and providing economical storage expansion options to accommodate your growing business needs.

UNRIVALED DURABILITY AND PROTECTION

Built to withstand demanding environments, the SecureNAS® boasts a durable design that ensures durability and protection. Manufactured in the USA and US military-approved Environmental Testing Lab certified, this NAS guarantees excellence in hardware encryption, mechanical design, capacity, security, and maintenance.

Choose SecureNAS for unparalleled security, reliability, and performance. Safeguard your valuable data with a trusted partner that puts your peace of mind first.



SecureNAS® CX-40KSSD

- Up to 120TB storage capacity
- 4-Bay NAS with hot-swappable 2.5" SSDs and two internal 2.5" SSDs for the operating system
- Certified by a US military-approved Environmental Testing Lab
- Ruggedized Portable Systems
- Ciphertex SecureNAS® Encryption is FIPS 140-2 Level 3 Certified
- Ciphertex Protect® Hardware Encryption Keys for secure data management
- Intel Xeon D processor (4, 8, 16 Core)
- DDR4 memory options, ranging from 32GB-128GB for optimal high-performance
- Intel AES-NI for bulk encryption/decryption, authentication, and random number generation
- Two PCIe slots support multiple network interface cards for cross-communication across different networks, graphics support, and various applications including file sharing, backup, disaster recovery, iSCSI, virtualization & business applications
- Lockable metal security door to prevent theft and data loss by human error
- Complimentary 2 x 10G Fiber
- USB blocker for enhanced security
- Compact footprint for space efficiency
- Instant Secure Erase
- High-speed duplicate and transfer between local and remote servers with Rsync
- Supporting ZFS resiliency. ZFS RAIDZ levels: Mirror, Stripe Set and RAIDZ1
- License Free (Operating system)

CAPACITY	PART NUMBER
8TB	SNCX-40KSSD-4C-32G-8TB
15TB	SNCX-40KSSD-4C-32G-15TB
30TB	SNCX-40KSSD-4C-32G-30TB
60TB	SNCX-40KSSD-4C-32G-60TB
120TB	SNCX-40KSSD-4C-32G-120TB



Government Applications

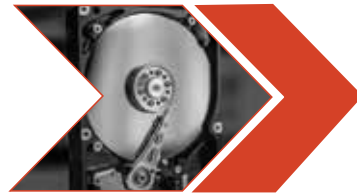

IMPORTANT: Determine your useable data needs. Use Ciphertex Raid Calculator @ ciphertex.com/raid-calculator/ to decide the correct system to purchase.

SSD ←



UP TO 60TB



UP TO 240TB

SecureNAS® CX-80KSSD

- Up to 60TB storage capacity
- 8-Bay NAS with hot-swappable 2.5" SSDs and two internal 2.5" SSDs for the operating system
- Durable Portable Systems
- Certified by a US military-approved Environmental Testing Lab
- Ciphertex SecureNAS® Encryption is FIPS 140-2 Level 3 Certified
- Ciphertex Protect® Hardware Encryption Keys for secure data management
- Intel Xeon D processor (4, 8, 16 Core)
- DDR4 memory options, ranging from 32GB-128GB for optimal high-performance
- Intel AES-NI for bulk encryption/decryption, authentication, and random number generation
- Two PCIe slots support multiple network interface cards for cross-communication across different networks, graphics support, and various applications including file sharing, backup, disaster recovery, iSCSI, virtualization & business applications
- Lockable metal security door to prevent theft and data loss by human error
- Complimentary 2 x 10G Fiber
- USB blocker for enhanced security
- Compact footprint for space efficiency
- Instant Secure Erase
- High-speed duplicate and transfer between local and remote servers with Rsync
- Supporting ZFS resiliency. ZFS RAIDZ levels: Mirror, Stripe Set, RAIDZ1 and RAIDZ2
- License Free (Operating system)

CAPACITY	PART NUMBER
15TB	SNCX-80KSSD-4C-32G-15TB
30TB	SNCX-80KSSD-4C-32G-30TB
60TB	SNCX-80KSSD-4C-32G-60TB

SecureNAS® CX-80KSSD-X

- Up to 240TB storage capacity
- 8-Bay NAS with hot-swappable 2.5" SSDs and two internal 2.5" SSDs for the operating system
- Certified by a US military-approved Environmental Testing Lab
- Ruggedized Portable Systems
- Ciphertex SecureNAS® Encryption is FIPS 140-2 Level 3 Certified
- Ciphertex Protect® Hardware Encryption Keys for secure data management
- Intel Xeon D processor (4, 8, 16 Core)
- DDR4 memory options, ranging from 32GB-128GB for optimal high-performance
- Intel AES-NI for bulk encryption/decryption, authentication, and random number generation
- Two PCIe slots support multiple network interface cards for cross-communication across different networks, graphics support, and various applications including file sharing, backup, disaster recovery, iSCSI, virtualization & business applications
- Lockable metal security door to prevent theft and data loss by human error
- Complimentary 2 x 10G Fiber
- USB blocker for enhanced security
- Compact footprint for space efficiency
- Instant Secure Erase
- High-speed duplicate and transfer between local and remote servers with Rsync
- Supporting ZFS resiliency. ZFS RAIDZ levels: Mirror, Stripe Set, RAIDZ1 and RAIDZ2
- License Free (Operating system)

CAPACITY	PART NUMBER
30TB	SNCX-80KSSD-X-4C-32G-30TB
60TB	SNCX-80KSSD-X-4C-32G-60TB
120TB	SNCX-80KSSD-X-4C-32G-120TB
240TB	SNCX-80KSSD-X-4C-32G-240TB



Media Entertainment Applications

▶▶ SSD

SSD ◀◀



SecureNAS® CX-120KSSD-X Hybrid

- Up to 272TB storage capacity
- 12-Bay NAS with hot-swappable 2.5" SSDs and two internal 2.5" SSDs for the operating system
- Certified by a US military-approved Environmental Testing Lab
- Durable Portable Systems
- Ciphertex SecureNAS® Encryption is FIPS 140-2 Level 3 Certified
- Ciphertex Protect® Hardware Encryption Keys for secure data management
- Intel Xeon D processor (4, 8, 16 Core)
- DDR4 memory options, ranging from 32GB-128GB for optimal high-performance
- Intel AES-NI for bulk encryption/decryption, authentication, and random number generation
- Two PCIe slots support multiple network interface cards for cross-communication across different networks, graphics support, and various applications including file sharing, backup, disaster recovery, iSCSI, virtualization & business applications
- Lockable metal security door to prevent theft and data loss by human error
- Complimentary 2 x 10G Fiber
- USB blocker for enhanced security
- Compact footprint for space efficiency
- Instant Secure Erase
- High-speed duplicate and transfer between local and remote servers with Rsync
- Supporting ZFS resiliency. ZFS RAIDZ levels: Mirror, Stripe Set, RAIDZ1 and RAIDZ2
- License Free (Operating system)

CAPACITY	PART NUMBER
255TB	SNCX-120KSSD-X-4C-32G-255TB
272TB	SNCX-120KSSD-X-4C-32G-270TB

SecureNAS® CX-160KSSD-X

- Up to 480TB storage capacity
- 16-Bay NAS with hot-swappable 2.5" SSDs and two internal 2.5" SSDs for the operating system
- Certified by a US military-approved Environmental Testing Lab
- Ruggedized Portable Systems
- Ciphertex SecureNAS® Encryption is FIPS 140-2 Level 3 Certified
- Ciphertex Protect® Hardware Encryption Keys for secure data management
- Intel Xeon D processor (4, 8, 16 Core)
- DDR4 memory options, ranging from 32GB-128GB for optimal high-performance
- Intel AES-NI for bulk encryption/decryption, authentication, and random number generation
- Two PCIe slots support multiple network interface cards for cross-communication across different networks, graphics support, and various applications including file sharing, backup, disaster recovery, iSCSI, virtualization & business applications
- Lockable metal security door to prevent theft and data loss by human error
- Complimentary 2 x 10G Fiber
- USB blocker for enhanced security
- Compact footprint for space efficiency
- Instant Secure Erase
- High-speed duplicate and transfer between local and remote servers with Rsync
- Supporting ZFS resiliency. ZFS RAIDZ levels: Mirror, Stripe Set, RAIDZ1, RAIDZ2, and RAIDZ3
- License Free (Operating system)

CAPACITY	PART NUMBER
60TB	SNCX-160KSSD-X-4C-32G-60TB
120TB	SNCX-160KSSD-X-4C-32G-120TB
240TB	SNCX-160KSSD-X-4C-32G-240TB
480TB	SNCX-160KSSD-X-4C-32G-480TB

Higher-capacity **HDDs** deliver an **MTBF3** of up to **2.5 million hours**, enabling enterprise and data center expansion and efficiency.

HDD 



SecureNAS® CX-40KHD

- Up to 88TB storage capacity
- 4-Bay NAS with hot-swappable 3.5" HDDs and two internal 2.5" SSDs for the operating system
- Certified by a US military-approved Environmental Testing Lab
- Ruggedized Portable Systems
- Ciphertex SecureNAS® Encryption is FIPS 140-2 Level 3 Certified
- Ciphertex Protect® Hardware Encryption Keys for secure data management
- Intel Xeon D processor (4, 8, 16 Core)
- DDR4 memory options, ranging from 32GB-128GB for optimal high-performance
- Intel AES-NI for bulk encryption/decryption, authentication, and random number generation
- Two PCIe slots support multiple network interface cards for cross-communication across different networks, graphics support, and various applications including file sharing, backup, disaster recovery, iSCSI, virtualization & business applications
- Customizable security options and pre-installed software to specifications
- Lockable metal security door to prevent theft and data loss by human error
- Complimentary 2 x 10G Fiber
- USB blocker for enhanced security
- Compact footprint for space efficiency
- Instant Secure Erase
- High-speed duplicate and transfer between local and remote servers with Rsync
- Supporting ZFS resiliency. ZFS RAIDZ levels: Mirror, Stripe Set, RAIDZ1 and RAIDZ2
- License Free (Operating system)

CAPACITY	PART NUMBER
16TB	SNCX-40KHD-4C-32G-16TB
24TB	SNCX-40KHD-4C-32G-24TB
40TB	SNCX-40KHD-4C-32G-40TB
48TB	SNCX-40KHD-4C-32G-48TB
64TB	SNCX-40KHD-4C-32G-64TB
72TB	SNCX-40KHD-4C-32G-72TB
80TB	SNCX-40KHD-4C-32G-80TB
88TB	SNCX-40KHD-4C-32G-88TB



SecureNAS® CX-80KHD-X

- Up to 176TB storage capacity
- 8-Bay NAS with hot-swappable 3.5" HDDs and two internal 2.5" SSDs for the operating system
- Certified by a US military-approved Environmental Testing Lab
- Ruggedized Portable Systems
- Ciphertex SecureNAS® Encryption is FIPS 140-2 Level 3 Certified
- Ciphertex Protect® Hardware Encryption Keys for secure data management
- Intel Xeon D processor (4, 8, 16 Core)
- Intel AES-NI for bulk encryption/decryption, authentication, and random number generation
- DDR4 memory options, ranging from 32GB-128GB for optimal high-performance
- Two PCIe slots support multiple network interface cards for cross-communication across different networks, graphics support, and various applications including file sharing, backup, disaster recovery, iSCSI, virtualization & business applications
- Customizable security options and pre-installed software to specifications
- Lockable metal security door to prevent theft and data loss by human error
- Complimentary 2 x 10G Fiber
- USB blocker for enhanced security
- Compact footprint for space efficiency
- Instant Secure Erase
- High-speed duplicate and transfer between local and remote servers with Rsync
- Supporting ZFS resiliency. ZFS RAIDZ levels: Mirror, Stripe Set, RAIDZ1 and RAIDZ2
- License Free (Operating system)

CAPACITY	PART NUMBER
64TB	SNCX-80KHD-X-4C-32G-64TB
80TB	SNCX-80KHD-X-4C-32G-80TB
96TB	SNCX-80KHD-X-4C-32G-96TB
128TB	SNCX-80KHD-X-4C-32G-128TB
144TB	SNCX-80KHD-X-4C-32G-144TB
160TB	SNCX-80KHD-X-4C-32G-160TB
176TB	SNCX-80KHD-X-4C-32G-176TB



▶▶ HDD



SecureNAS® CX-120KHD-X Hybrid

- Up to 206TB storage capacity
- 12-Bay NAS with hot-swappable 8x3.5" HDDs and 4x2.5" SSDs, and two internal 2.5" SSDs for the operating system
- Certified by a US military-approved Environmental Testing Lab
- Ruggedized Portable Systems
- Ciphertex SecureNAS® Encryption is FIPS 140-2 Level 3 Certified
- Ciphertex Protect® Hardware Encryption Keys for secure data management
- Intel Xeon D processor (4, 8, 16 Core)
- DDR4 memory options, ranging from 32GB-128GB for optimal high-performance
- Intel AES-NI for bulk encryption/decryption, authentication, and random number generation
- Two PCIe slots support multiple network interface cards for cross-communication across different networks, graphics support, and various applications including file sharing, backup, disaster recovery, iSCSI, virtualization & business applications
- Customizable security options and pre-installed software to specifications
- Lockable metal security door to prevent theft and data loss by human error
- Complimentary 2 x 10G Fiber
- USB blocker for enhanced security
- Compact footprint for space efficiency
- Instant Secure Erase
- High-speed duplicate and transfer between local and remote servers with Rsync
- Supporting ZFS resiliency. ZFS RAIDZ levels: Mirror, Stripe Set, RAIDZ1 and RAIDZ2
- License Free (Operating system)

CAPACITY	PART NUMBER
191TB	SNCX-120KHD-X-4C-32G-191TB
206TB	SNCX-120KHD-X-4C-32G-206TB

HDD ◀◀



SecureNAS® CX-160KHD-X

- Up to 352TB storage capacity
- 16-Bay NAS with hot-swappable 3.5" HDDs and two internal 2.5" SSDs for the operating system
- Certified by a US military-approved Environmental Testing Lab
- Ruggedized Portable Systems
- Ciphertex SecureNAS® Encryption is FIPS 140-2 Level 3 Certified
- Ciphertex Protect® Hardware Encryption Keys for secure data management
- Intel Xeon D processor (4, 8, 16 Core)
- Intel AES-NI for bulk encryption/decryption, authentication, and random number generation
- Two PCIe slots support multiple network interface cards for cross-communication across different networks, graphics support, and various applications including file sharing, backup, disaster recovery, iSCSI, virtualization & business applications
- DDR4 memory options, ranging from 32GB-128GB for optimal high-performance
- Customizable security options and pre-installed software to specifications
- Lockable metal security door to prevent theft and data loss by human error
- Complimentary 2 x 10G Fiber
- USB blocker for enhanced security
- Compact footprint for space efficiency
- Instant Secure Erase
- High-speed duplicate and transfer between local and remote servers with Rsync
- Supporting ZFS resiliency. ZFS RAIDZ levels: Mirror, Stripe Set, RAIDZ1, RAIDZ2, and RAIDZ3
- License Free (Operating system)

CAPACITY	PART NUMBER
128TB	SNCX-160KHD-X-4C-32G-128TB
160TB	SNCX-160KHD-X-4C-32G-160TB
192TB	SNCX-160KHD-X-4C-32G-192TB
256TB	SNCX-160KHD-X-4C-32G-256TB
288TB	SNCX-160KHD-X-4C-32G-288TB
320TB	SNCX-160KHD-X-4C-32G-320TB
352TB	SNCX-160KHD-X-4C-32G-352TB



Forensic Applications

▶▶ **HDD**

HDD ◀◀



SecureNAS® 40KHD JBOD (4-Bay)

Ciphertex CX-40KHD JBOD (JUST A BUNCH OF DISKS) and then some (up to 88TB of expansion storage) is an expansion unit designed for the SecureNAS® Series. JBOD units increase capacity and efficiency at a significantly lower cost than NAS systems because they do not contain a motherboard and other expensive components. For example, when a 4-bay CX-JBOD is connected to a SecureNAS® CX-160KHD-X (16-bay), the total raw capacity is 400TB or almost half a petabyte.

Features include:

- Drive pools and settings can be configured from the SecureNAS®'s web interface, providing additional storage options for companies that need to store data at rest or in transit
- CX-JBODs may also be used as direct attached storage (DAS) solution for local backup
- All SecureNAS® systems can connect to multiple 4- and 8-bay JBODs to increase the NAS's overall capacity
- Sturdy enclosure ensures military-grade durability and transportability in all environments
- Comes with any requested number of FIPS 140-2 Level 3 validated Ciphertex Protect® Encryption Keys (once activated, the device's volumes are only accessible when the key is inserted)
- Certified by a US military-approved Environmental Testing Lab

SecureNAS® 80KHD JBOD (8-Bay)

Ciphertex CX-80KHD JBOD (JUST A BUNCH OF DISKS) and then some (up to 176TB of additional HDD storage) is an expansion unit designed for the SecureNAS® Series. JBOD units increase capacity and efficiency at a significantly lower cost than NAS systems because they do not contain a motherboard and other expensive components. For example, when an 8-bay CX-JBOD is connected to SecureNAS® CX-160KHD-X (16-bay), the total raw capacity is 480TB, or almost one-half of a petabyte.

Features include:

- Configure drive pools and settings from SecureNAS®'s web interface, providing additional storage options for companies that need to store data at rest or in transit
- CX-JBODs may also be used as direct attached storage (DAS) solution for local backup
- All SecureNAS® systems can connect to multiple 4- and 8-bay JBODs to increase the NAS's overall capacity
- Sturdy enclosure ensures military-grade durability and transportability in all environments
- Comes with any requested number of FIPS 140-2 Level 3 validated Ciphertex Protect® Encryption Keys (once activated, the device's volumes are only accessible when the key is inserted)
- Certified by a US military-approved Environmental Testing Lab



Artificial Intelligence Applications

Vastly improve data transfer speeds and workflow with support of up to 64,000 I/O queues, superior security, and energy-efficiency with NVMe.

NVMe (Non-volatile Memory Express) has revolutionized server infrastructure. NVMe servers are specifically designed with NVMe SSD, offering exceptional performance and ultra-fast response times for various enterprise workloads. NVMe, a storage, access, and transport protocol, was developed to accelerate data transfer between enterprise and client systems and solid-state drives, utilizing the PCI Express (PCIe) bus. Essentially, NVMe represents cutting-edge technology for accessing flash memory in solid-state drives (SSDs).

Key Functions of NVMe in Servers

NVMe's remarkable features enable servers equipped with NVMe drives to outperform their counterparts with older drivers, enabling faster input/output operations and facilitating the transfer of larger data volumes. The key functions of NVMe in servers include:

Direct CPU Connection: NVMe drives connect directly to the CPU via the PCIe interface. This direct connection through the PCI Express bus allows NVMe drives to deliver more input/output operations per second (IOPs). NVMe can support and simultaneously handle up to 64k queues.

Low Latency: NVMe drives exhibit incredibly low latency, with an average of only 2.8 microseconds. This latency level is significantly lower compared to other drive technologies, further enhancing the overall performance and responsiveness of NVMe servers.

Advantages of NVMe Servers

NVMe drives boast impressive read speeds of around 3GB/s and write rates ranging from 1.5-2GB/s. In comparison, most SATA SSDs only manage read and write speeds of approximately 550MB/s. This stark contrast positions NVMe servers as the superior choice for performance. Designed to accommodate more extensive and deeper queues, NVMe enables more commands to be processed concurrently. This optimization empowers servers with NVMe SSDs to achieve significantly higher concurrent IOPS (input/output operations per second), enhancing their performance capabilities.

The Advantages of Adopting NVMe

Enhanced Performance: NVMe's optimized design enables faster data transfer, reduced latency, and increased input/output operations per second (IOPS), significantly improving overall system performance.

Scalability: NVMe facilitates seamless scalability, allowing businesses to expand their data processing capabilities to keep pace with growing demands and evolving technologies.

Efficient Data Management: With NVMe, enterprises can efficiently store, manage, and access large volumes of data, enabling streamlined workflows and quicker decision-making processes.

Improved Reliability: NVMe's advanced features, including enhanced error correction mechanisms and end-to-end data protection, ensure the integrity and reliability of stored data.

Consistency and Quality of Service: NVMe's superior performance and robustness contribute to consistent and reliable service delivery, eliminating performance bottlenecks and ensuring a seamless user experience.

NVMe



SecureNAS® CX-140KNVMe (14-Bay all NVMe)

- Up to 420TB storage capacity
- Supports 14 hot-swappable NVMe SSDs and 2 mirrored internal SSDs for fail-safe OS hosting
- High-performing enterprise NAS engineered to accelerate workflow, collaborations, file transfers, blocks and object storage applications
- Certified by a US military-approved Environmental Testing Lab
- Ruggedized Portable Systems
- Ciphertex SecureNAS® Encryption is FIPS 140-2 Level 3 Certified
- Ciphertex Protect® Hardware Encryption Keys
- Tamper-Proof Encryption Key for secure data management
- Powered by an AMD® EPYC™ Series (ROME) 24-core processor
- Supports DDR4 RDIMM, LRDIMM, NVDIMM
- The all-NVMe SSD architecture reduces latency, improves bandwidth, and substantially increases sequential and random read/write speed
- Two PCIe slots support multiple network interface cards for cross-communication across different networks, graphics support, and various applications including file sharing, backup, disaster recovery, iSCSI, virtualization & business applications
- Customizable security options and pre-installed software to specifications
- Lockable metal security door to prevent theft and data loss by human error
- Complimentary 2 x 10G Fiber
- USB blocker for enhanced security
- Compact footprint for space efficiency
- Instant Secure Erase
- High-speed duplicate and transfer between local and remote servers with Rsync
- Supporting ZFS resiliency. ZFS RAIDZ levels: Mirror, Stripe Set, RAIDZ1, RAIDZ2, and RAIDZ3
- License Free (Operating system).

CAPACITY	PART NUMBER
105TB	SNCX-140KNVME-4C-32G-105TB
210TB	SNCX-140KNVME-4C-32G-210TB
420TB	SNCX-140KNVME-4C-32G-420TB



FIPS NVMe Lightning Fast, Durable, Portable, Encrypted and Tamper-proof Rackmount

FIPS NVMe



UP TO 737TB



FIPS 140-2 is a U.S. government standard specifying security requirements for cryptographic modules, including hardware and software components. These requirements are designed to ensure that cryptographic modules provides security for protecting sensitive information and transactions. Some of the key security requirements include the following:

- 1. Cryptographic Module Specification**
A cryptographic module specifies physical and logical boundaries, interfaces, and security functions.
- 2. Roles and Services**
The cryptographic module provides roles and services, including key management, encryption, and authentication.
- 3. Cryptographic Algorithms**
Approved cryptographic algorithms can be used by the cryptographic module, along with specific requirements for key length, block size, and other parameters.
- 4. Key Management**
Custom requirements to generate, store, and protect cryptographic keys include key lifecycle management and destruction.
- 5. Physical Security**
Advanced measures protect the cryptographic module from unauthorized access, tampering, and theft.
- 6. Logical Security**
The module must have physical security mechanisms to prevent unauthorized modification of the module's firmware or software and a trusted path for sensitive data to ensure authorized components only process data.

SecureNAS® CX-2400K-R FIPS NVMe

Secure data anywhere with Ciphertex Portable Rackmount for ultra-low latency response rates and fast, reliable performance. Experience high-performance applications with our cutting-edge transportable SecureNAS® Server. These energy-efficient rackmount servers excel in diverse workloads and workflows. They are equipped with AMD EPYC 7003 series processors, with the option to add NVIDIA A2 GPU. Our SecureNAS® FIPS rack delivers exceptional performance across various assignments, producing faster results to increase business productivity. Whether dealing with professional computing tasks, data center operations, or engineering workloads, our servers offer the ideal solution for your most demanding requirements. Choose from a wide range of form factors to suit your specific needs. Our SecureNAS® servers provide the flexibility for optimal performance designed to adapt seamlessly to your infrastructure. At Ciphertex, we prioritize reliability and durability. Built with robust components to ensure long-term performance and stability, our Transportable SecureNAS® Server gives you the confidence to tackle any workload easily.



CAPACITY	PART NUMBER
376TB	SNCX-2400KFIPS-376TB
475TB	SNCX-2400KFIPS-475TB
737TB	SNCX-2400KFIPS-737TB

DIMENSIONS:
Width=17.24" Length=20.64" Height=5.06"

Tray and sliding rails for the SecureNAS® FIPS Rack available. See page 27 & 31 for details.

NVIDIA GPU Experience the Power of NVIDIA-SecureNAS®: Enhancing Enterprise Computing

The NVIDIA A2 PCIe Gen4 X8 card is up to 30% faster than the previous GPU leader. Discover the game-changing potential of NVIDIA SecureNAS® Systems™ in revolutionizing your enterprise computing infrastructure. Experience unmatched performance, reliability, and scalability, empowering you to deliver cutting-edge products and services while streamlining operations and boosting efficiency. From SecureNAS® to data center applications, trust NVIDIA to securely and efficiently run your accelerated workloads. Stay ahead of the competition with NVIDIA-SecureNAS®.



Rugged Transport Case

for portable rack mount available to prevent shock and vibration.





▶▶ NVMe

NVMe ◀◀

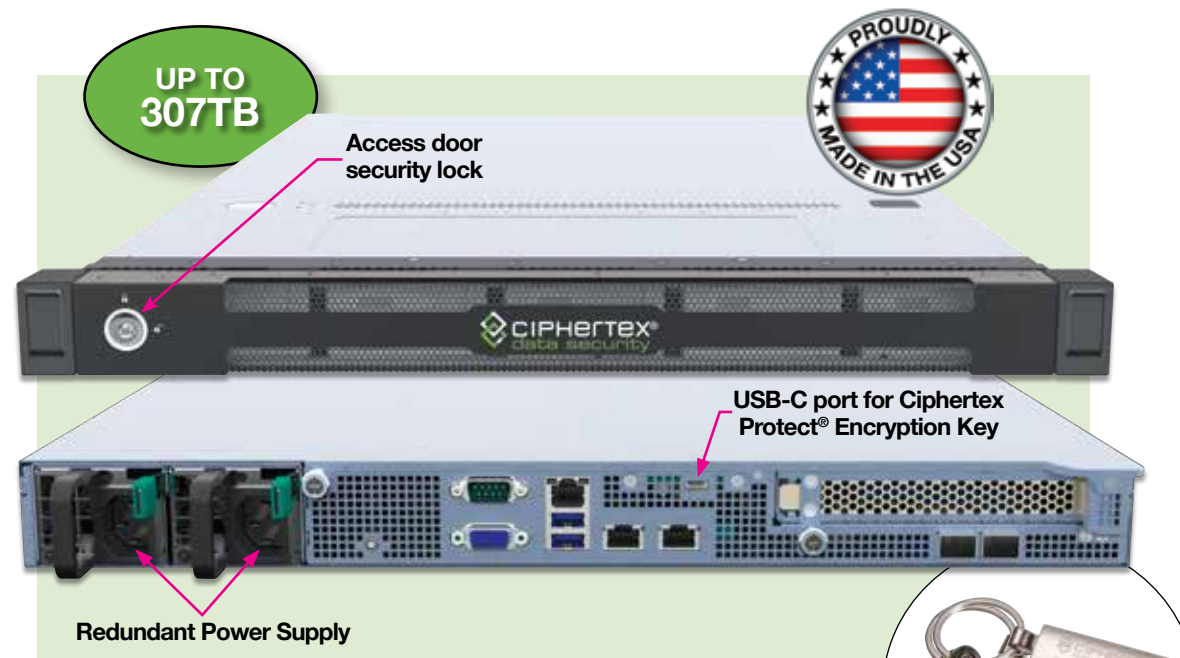

SecureNAS® CX-100K-R NVMe (10-Bay NVMe SSD)

Engineered for efficiency and security, our SecureNAS® CX-110K-R NVMe is a compact 1U Rackmount Server that packs unmatched compute power. Equipped with AMD's EPYC server processors, this system is optimized for heavy parallel workloads. Supporting DDR4 RDIMM, LRDIMM, and NV DIMM, it accommodates diverse memory needs. With 10 hot-swappable NVMe SSDs and mirrored internal SSDs for OS hosting, this powerhouse is built for performance. Its AMD EPYC Series (ROME) 24-core processor can upgrade to 64 cores and boasts Intel® AES-NI technology for fast and secure data encryption/decryption, enhancing security and reducing latency. The system's versatility is evident with PCIe Gen4 x 2 expansion slots for 100GbE/200GbE NICs. Ciphertex's SecureNAS® CX-100K-R NVMe offers cross-platform file sharing, automatic backups, virtual machine hosting, and ZFS RAIDZ resiliency. Enhanced security includes FIPS 140-2 Level 3 Physical Encryption Keys. Experience multi-core computing excellence for the most demanding applications. Customize connectivity and manage remotely with dual 10GbE LAN and dedicated IPMI 2.0 port. Virtualize confidently with high VM density and breakthrough performance. The SecureNAS® CX-100K-R NVMe delivers innovation, density, and exceptional performance. Pre-installed with RhinOS 24.1 software at no extra cost.

CAPACITY	PART NUMBER
156TB	SNCX-100NVME-156TB
307TB	SNCX-100NVME-307TB

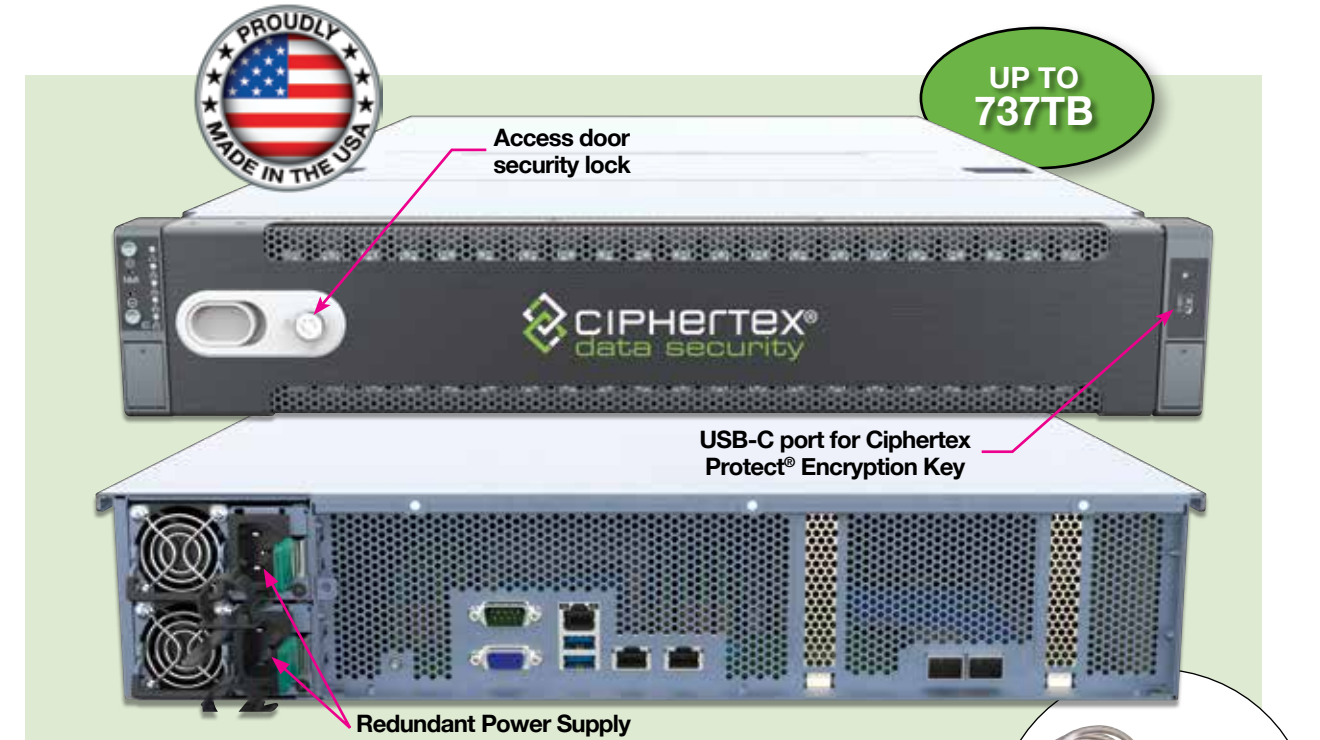

SecureNAS® CX-240K-R NVMe (24-Bay NVMe SSD)

A Blazing-Fast NVMe Server for Accelerated Data Access and Critical Workloads ranging from 360TB to 720TB All-NVMe Storage. The SecureNAS® CX-240K-R NVMe features 24 hot-swappable NVMe SSDs and two internal mirrored SSDs for OS hosting. Powered by an AMD EPYC Series (ROME) 24-core processor, upgradable to 64 cores, it boasts Intel® AES-NI technology for fast and secure data encryption/decryption, enhancing security and reducing latency. Supporting DDR4 RDIMM, LRDIMM, and NV DIMM, it accommodates diverse memory needs. The system's versatility is evident with PCIe Gen4 x 2 expansion slots for 100GbE/200GbE NICs. Ciphertex's SecureNAS® Rack NVMe CX-720K offers cross-platform file sharing, automatic backups, virtual machine hosting, and ZFS RAIDZ resiliency. Enhanced security includes FIPS 140-2 Level 3 Physical Encryption Keys. ZFS RAIDZ configurable: Mirror, Stripe Set, RAIDZ, RAIDZ2, and RAIDZ 3. Experience multi-core computing excellence for the most demanding applications. Customize connectivity and manage remotely with dual 10GbE LAN and dedicated IPMI 2.0 port. Virtualize confidently with high VM density and breakthrough performance. Includes pre-installed RhinOS 24.1 software at no extra cost.

CAPACITY	PART NUMBER
376TB	SNCX-240KNVME-376TB
575TB	SNCX-240KNVME-575TB
737TB	SNCX-240KNVME-737TB



Up to 2,640 4K movies or 1,560 8K movies can be stored on a 120TB SecureNas®
According to Fortra File Catalyst 2022 movie sizes



The F-16 Next Generation warfare plane communicates to Ciphertex SecureNas® which is transferred to classified data center

Prevent Piracy with the SecureNas® System.

Billions of dollars in revenue are lost each from piracy. Ciphertex® is your secure solution.

Popular Applications for Ciphertex® SecureNas® Portable Content Servers

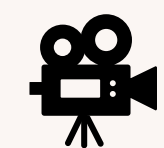

FILM:
Securely transfer footage safely from production to the data center.



MILITARY:
Securely transfer case-sensitive information via applications that require extreme portability while maintaining optimal security.



AIRLINES:
Securely transfer media content to prevent intellectual privacy theft for airlines.



HEALTHCARE:
Securely transfer HIPAA-sensitive medical data for patients so that doctors globally can work together to find cures and prevent disease.



FORENSIC:
Allows multiple examiners or investigators to examine evidence simultaneously and preserve the integrity of the chain of custody by compiling live evidence from the crime scene to move to the data center or forensic lab.

Expansion Interface Cards

SecureNAS® Rack Tray



The additional expansion slots allow you to customize your NAS to meet your business requirements. Check out these five most popular upgrades.

EXPANSION CARDS

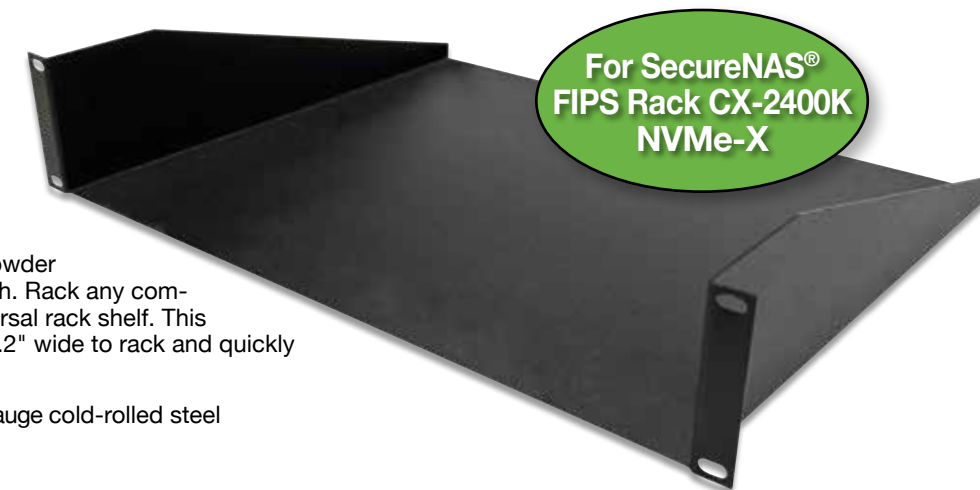
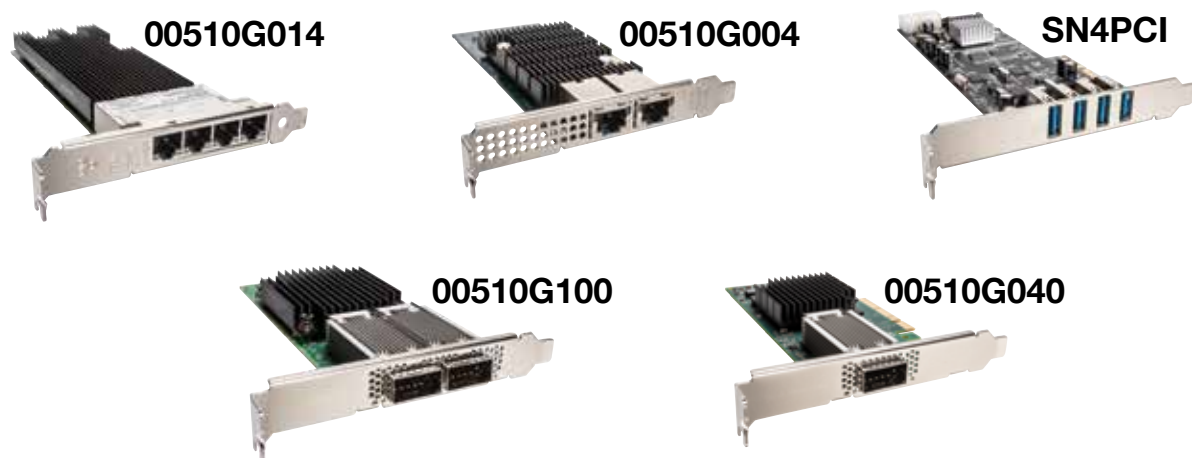

SecureNAS® FIPS Rack Tray

For use in any rack system, the 3 Space Utility Rack shelf is constructed of cold rolled steel for durability and has a tough black powder coat finish that won't rust or scratch. Rack any component up to 48 lbs. with this universal rack shelf. This versatile shelf fits all parts up to 17.2" wide to rack and quickly store everything.

- 3 Rack Spaces
- Made of 16-gauge cold-rolled steel
- 15 Inch Depth

For Sliding rails see page 31.

SecureNAS® Network Environment

Data Platform with Scalable Solutions for Large Enterprises

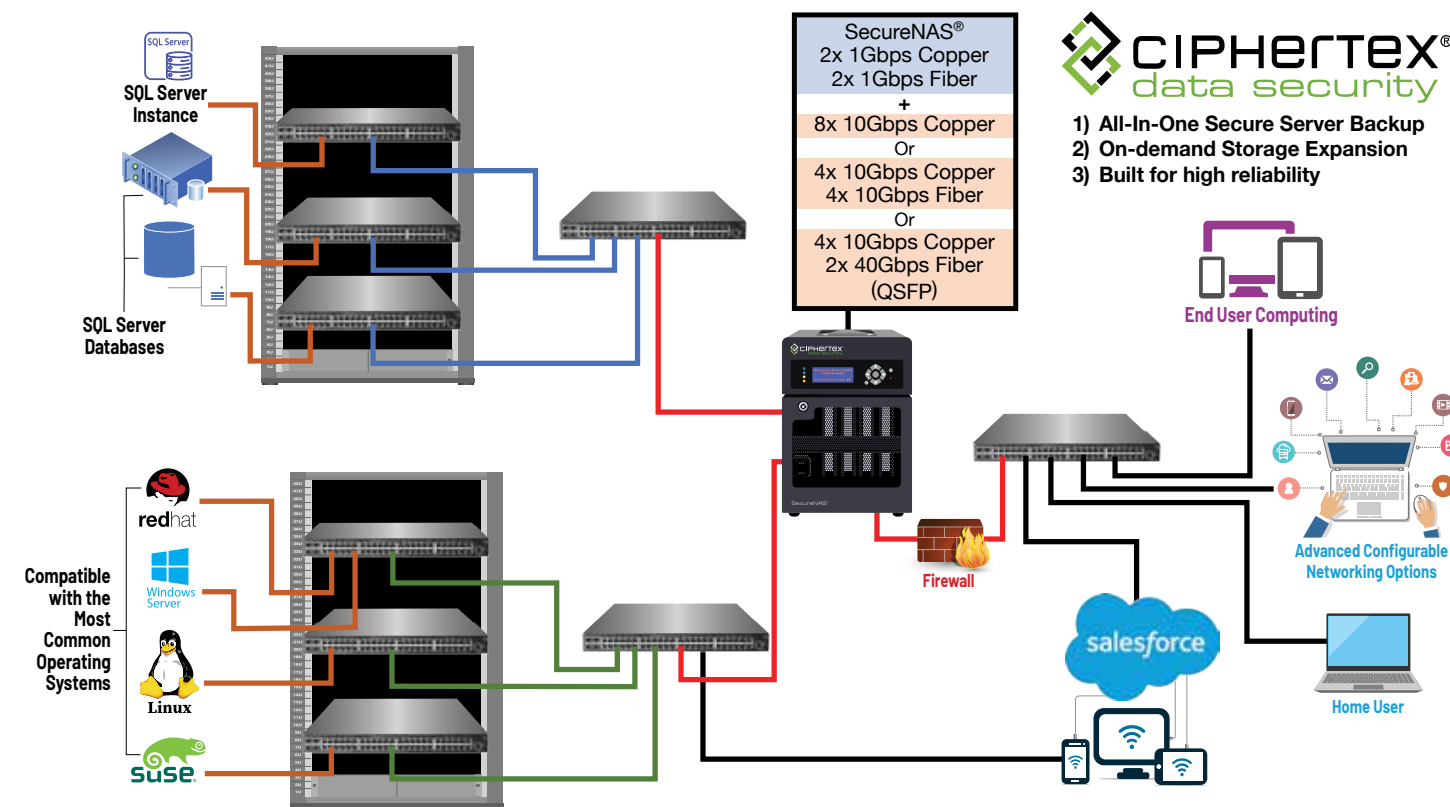

Devices with USB-C ports can also be connected to the NAS. For security, USB ports can be disabled to restrict unauthorized access.

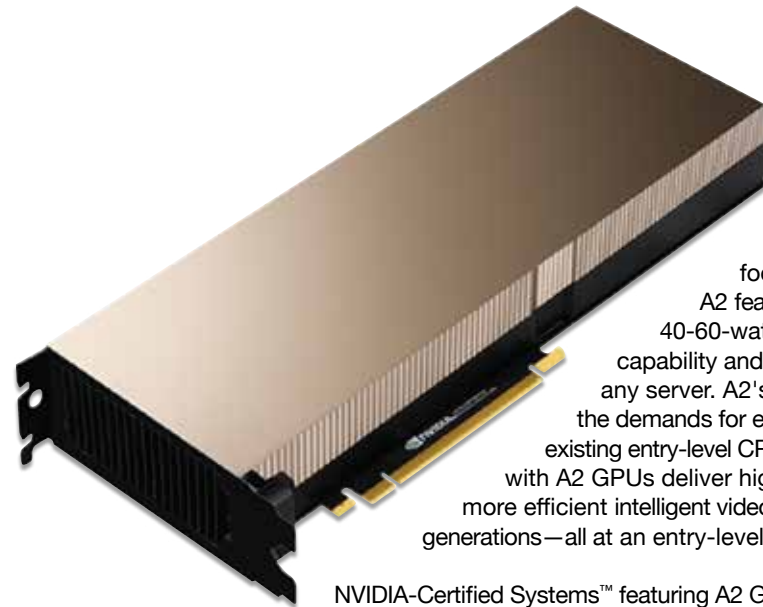

NVIDIA A2 GPU

Versatile Inference

The NVIDIA A2 Tensor Core GPU offers inference that uses little power, a minimum footprint, and high performance for NVIDIA AI. The A2 features a low-profile PCIe Gen4 card and a low 40-60-watt (W) configurable thermal design power (TDP) capability and brings adaptable inference acceleration to any server. A2's versatility, compact size, and low power exceed the demands for edge deployments at scale, instantly upgrading existing entry-level CPU servers to handle inference. Servers accelerated with A2 GPUs deliver higher inference performance versus CPUs and more efficient intelligent video analytics (IVA) deployments than previous GPU generations—all at an entry-level price point.

NVIDIA-Certified Systems™ featuring A2 GPUs and NVIDIA AI, including the NVIDIA Triton™ Inference Server, deliver breakthrough inference performance across the edge, data center, and cloud. These allow AI-enabled applications to deploy with fewer servers and less power, for easier deployments, quicker insights, and significantly lower costs.

Up to 20X More Inference Performance

AI inference is deployed to make consumer lives more convenient through real-time experiences and enables them to gain insights on trillions of end-point sensors and cameras. Unlike CPU-only servers, the servers built with NVIDIA A2 Tensor Core GPU offer up to 20X more inference performance, instantly upgrading any server to handle modern AI.

Powered by the NVIDIA Ampere Architecture

The NVIDIA Ampere architecture is designed for the age of elastic computing, delivering the performance and acceleration needed to power modern enterprise applications. Explore the heart of the world's highest-performing, flexible data centers.

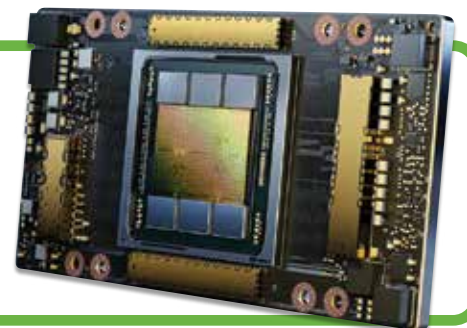

Highlights:

GPU Architecture	NVIDIA Ampere	INT8	36 TOPS 72 TOPS Sparsity
CUDA Cores	1280	INT4	72 TOPS 144 TOPS Sparsity
Tensor Cores	40 Gen 3	GPU Memory	16 GB GDDR6 ECC
RT Cores	108 Gen 2	Memory Bandwidth	200 GB/s
Peak FP32	4.5 TFLOPS	Thermal Solution	Passive
Peak TF32 Tensor Core	9 TFLOPS 18 TFLOPS Sparsity	Max Power Consumption	40-60 Watt Configurable
Peak FP16 Tensor Core	18 TFLOPS 36 TFLOPS Sparsity	System Interface	PCIe Gen 4.0 x8



Encrypted Portable Single Drive CX-2500E-SSD

NIST/FIPS 140-2 Level 3 Certified Encrypted Data Transfer in your Pocket Up to 8TB of SSD Storage. With its compact, sturdy design and FIPS 140-2 (Level 3) Certification, the CX-2500E-SSD makes it simple to secure and encrypt all your content, including high-resolution videos, photos, and mission-critical files.

Your data can only be accessed with an AES 256-bit encrypted Data Encryption Key (DEK) for worry-free transportation and storage. These portable drives deliver rapid file transfer speeds (up to 3,000 MBITS/s) and proven reliability for Mac and PC users. Providing up to 8TB in a single SSD drive, this device is one of the most versatile portable external drives. They were designed for peak performance while operating at an optimal temperature.

The bus-power feature offers the user added convenience by eliminating the need to carry the hefty adaptors and cables required to power typical hard drives.

Experience the Ciphertex CX-2500E-SSD Advantage

The CX-2500E-SSD is the go-to FIPS 140-2 level 3 certified, AES 256-bit encrypted mobile security drive for forensics, healthcare, media and entertainment, government and military agencies. The easy-to-use Data Encryption Keys make it possible to encrypt and secure your data in transit or remotely.

Features:

- USB 3.0 Connectivity. Includes long; 32" enterprise USB 3.0 cable
- FIPS 140-2 Certified, AES-256 encryption for your classified data
- Up to 7.6TB SSD
- Bus-powered and bootable encryption enables secure program and data access via an external drive
- AES 256-bit Advanced Encryption Algorithm
- Zero-time encryption and decrypting that maintains drive performance
- Durable aluminum enclosure for enhanced cooling and protection
- Shock absorbers protect the drive and suppress noise
- 2-Year Warranty

SecureNAS® Military-Grade Transport Case for CX-2500E-SSD

The case and its interior are designed according to SecureNAS® specifications for a custom, snug fit. SecureNAS® Transport cases are constructed with ultra-high impact structural multi-polymer along with durable tailor made interiors, making them extremely rugged.





Are you a manufacturer's rep or freelance salesperson looking for a partnership that will lead to success?

Our top-quality data security products are in high demand, and partnering with us offers numerous benefits. Here are just a few reasons why you should consider adding Ciphertex to your product lineup:

- Ciphertex is a trusted and established name in the data security industry
- Our products are designed and manufactured to the highest standards, ensuring reliable protection for your customer's data.
- As a Ciphertex partner, you'll have access to exceptional support and training, giving you the knowledge and skills you need to sell our products effectively.
- Our team will work with you on custom design projects, providing software and hardware solutions.
- Our dedicated technical experts are ready to help you resolve any issue, ensuring your clients can keep their business moving smoothly and securely.
- Access to unique program benefits and discounts to help you grow your business, including help with sales and marketing, expert training, and technical support.

Take advantage of the opportunity to partner with Ciphertex and add our products to your lineup. Join us today and start on the path to success.

BUILDING TRUST IN THE DIGITAL ERA:

Protecting Your Data
with Confidence



In an increasingly interconnected world, safeguarding data has never been more crucial. Digital assurance, secure encryption, reliable transmission, and robust data authentication are the fundamental cornerstones of data security. Whether your data is in motion or at rest, its protection is paramount. This is where Ciphertex steps in. With Ciphertex, you can trust that your data is fortified. We employ state-of-the-art encryption techniques, secure transmission protocols, and stringent data authentication measures to ensure the utmost security for your valuable information.

Our SecureNAS[®], paired with a powerful hardware encryption key called Ciphertex Protect[®], acts as an impenetrable shield for your data, generating a secure environment where confidentiality is paramount. With a decade of hands-on experience, Ciphertex[®] Data Security has emerged as the industry leader in portable and cyber security solutions, setting the global standard for data protection. We address the entire information security lifecycle, making digital assurance the cornerstone of our approach. Our expertise extends to securing the digital transformation of the most demanding entities, including military organizations, government bodies, private firms, and critical infrastructure providers.

At Ciphertex, we understand the intricacies of your industry, enabling us to meet and exceed customer expectations consistently from key generation to secure transportation and even key revocation. Our deep industry insight allows us to tailor our solutions to your unique requirements. Working closely with the US Military and Federal agencies, we leverage strong government-private sector partnerships to successfully deploy our SecureNAS[®] systems worldwide. Choose Ciphertex and join the ranks of those who trust us to fortify their data in the digital realm. Digital trust is not just a concept; it's a guarantee.



10G Cable

10G Cable- Each transceiver module is individually tested to be used on a series of switches, routers, servers, network interface card (NICs), etc. Designed for multi-gigabit data rates up to 10.5 Gbps, and compliant with SFP mechanical (SFF-8431) and electrical interface (SFF-8432) standards

Features:

- Low power consumption
- Easy installation
- High-performance integrated duplex serial data links for bidirectional communication
- Hot-swappable
- Ideal for enterprise networking for LAN applications



40G Cable

Direct Attach Cable operates over passive copper, requiring no additional power to ensure quality connectivity. This breakout cable is compliant with government regulatory standards. It provides a connection of 40G ports on both ends and is suitable for cost-effective close-range interconnections within your data center.

Features:

- Low power consumption
- Easy installation
- High-performance integrated duplex serial data links for bidirectional communication
- Hot-swappable



10G Converter

Ciphertex converters provide media conversions and distance extensions for 10G Ethernet links, meeting and growing need for more bandwidth for data centers and enterprises. These converters are hot-swappable with two QSFP+ sockets for 10G QSFP+ transceivers. The installation and setup is simple plug and play.



10GBASE-T SFP+ Copper RJ-45 30m Optical Transceiver Module

SFP+ transceiver provides 10GBase-T throughput up to 30m over cat6a/cat7 copper cable via RJ-45 connector. Compliant with IEEE 802.3an, IEEE 802.3az, SFF-8431 and SFP+ MSA. Features low power consumption, is hot swappable and ideal for enterprise networking for LAN applications and different other networking places using copper connections.



0050PB160



0050PB40



0050PB80



Hard Transport Cases

Completely protect Ciphertex NAS storage servers during shipment via common carrier. Cell-core construction helps to transport and protect the Ciphertex NAS storage server in the most extreme conditions on Earth. The polymer O-ring seals out dust and water, while the Gore-Tex automatic pressure equalization valve allows air molecules to pass through, preventing a "vacuum lock." The padlock on the case is mechanically reinforced to bolster security, reduce cutting, and minimize the chance of theft.

- Airtight, watertight, rustproof, shockproof, and crushproof
- Impervious to the rigors of Mother Nature
- Chemical resistance and corrosion proof
- Customizable Durable Foam that lasts 15 Years
- Automatic Pressure Equalization Valve.
- O-ring Seal
- Stainless Steel Hasp Protectors
- Wheels with Stainless Steel Bearings
- Retractable Extension Handle and Fold Down Handles
- Pockets for Accessories and Cables
- Optional Humidity Indicator Plug
- 7-Year Warranty



Sliding Rails for Rack Mount Tray

Mount multiple servers in one rack with the option to work on the server hardware. When another server is mounted directly above, a server can be pulled out of the rack from the front.

SPECIFICATIONS FOR ALL Portable SecureNAS® Servers

MODEL	CX-40KHD	CX-80KHD-X	CX-120KHD-X	CX-160KHD-X	CX-40KSSD	CX-80KSSD	CX-80KSSD-X	CX-120KSSD-X	CX-160KSSD	CX-140KNVMe
Drive Bay	Up to 4 hot-swappable 3.5" HDDs and 2 internal SSDs – Up to 88TB RAW storage capacity	8 hot-swappable 3.5" HDDs or 8 2.5" SSDs and 2 internal SSD's – Up to 176TB capacity	Up to 8 hot swappable 3.5" HDDs, 4 hot-swappable 2.5" SSDs and 2 internal SSD's – Up to 206TB capacity	16 hot-swap 3.5" HDDs and 2 internal SSDs – Up to 352TB RAW storage capacity	4 hot-swap 2.5" SSDs and 2 internal OS SSD's (up to 120 TB capacity)	8 hot-swappable 2.5" SSDs and 2 internal SSDs – Up to 64TB capacity	8 hot-swappable 2.5" SSDs and 2 internal SSDs – Up to 240TB capacity	Up to 12 hot-swappable 2.5" SDDs and 2 internal SSD's – Up to 272TB capacity	16 hot-swappable 2.5" SSDs and 2 internal SSDs – Up to 480TB storage capacity	Up to 14 hot-swappable NVMe SSDs and 2 mirrored internal SSDs – Up to 420TB storage capacity
High Performance CPU	Intel® Xeon® Processor D-1518 Socket FCBGA 1667 supported CPU TDP support 35W									AMD® EPYCTM 7002 Series
Cores/Cache	4 Cores (upgradable to 8 and 16 Cores), 8 Threads /6MB Cache									24 cores upgradable to 64 cores, 48 Threads / 256MB L3 Cache Socket
Memory Capacity	Up to 128GB Unbuffered ECC/non- ECC UDIMM, DDR4- 2133MHz, in 4 DIMM slots									Eight Channel DDR4 memory technology / Supports DDR4 RDIMM, LRDIMM
Memory Type	2133/1866/1600MHz ECC DDR4 ECC RDIMM and ECC/Non-ECC UDIMM									
Dimm Sizes	4GB, 8GB, 16GB, 32GB									RDIMM: 64GB
Memory Voltage	1.2 V									
Error Detection	Corrects single-bit errors, detects double-bit errors (using ECC memory)									
M.2 Expansion	M.2 Interface: 1 SATA/PCI-E 3.0 x4									N/A
SAS2	Broadcom 2116 SW controller for 16 SATA3 (6Gbps) ports; SAS2 and SATA3									N/A
IPMI	Support for Intelligent Platform Management Interface v.2.0 IPMI 2.0 with virtual media over LAN and KVM- over-LAN support									N/A
Network Controllers	Dual LAN with 10G SFP+ from D-1500 SoC; Dual LAN with 1GbE w/ Intel® I210									Dual RJ45 10G base-T by Intel® X550-AT2
Graphics	Aspeed AST2400 BMC									Aspeed AST2500, VRAM DDR4 256MB
LED Indicators	Status/Power, USB, LAN									N/A
Push Buttons	Power, Reset, Copy									N/A
Operating Temperature	0 – 60°C (32°F – 140°F)									OP: 10°C – 35°C / NON-OP: -40°C – 70°C
LAN Controllers	N/A									SATA CONTROLLER 4 x SATA3 6.0 Gb/s (from mini SAS HD, Gen3)
Slimline	N/A									Slimline x7 (PCIe Gen4 x 8)
Smart Cooling Fan	1 x 12cm (12V DC)									3 x 12cm (12V DC)
Weight	12.8 lbs (w/o drives)	20.5 lbs (w/o drives)	32 lbs (w/o drives); Approx. 51 lbs (w/drives)	12.8 lbs (w/o drives)	20.5 lbs (w/o drives)	32 lbs (w/o drives); Approx. 39 lbs (w/SSD drives)	26 lbs (w/o drives); Approx. 33 lbs (w/drives)			
Size	Height: 9.8" (243 mm) Width: 7.0" (178 mm) Depth: 9.5" (241 mm)	Height: 9.8" (248.92 mm) Width: 11.25" (285.75 mm) Depth: 9.75" (247.65 mm)	Height: 15.25" (387.35 mm) Width: 11.25" (285.75 mm) Depth: 10.5" (266.75 mm)	Height: 9.8" (243 mm) Depth: 9.5" (241 mm)	Width 7.0" (178 mm)	Height: 9.8" (248.92 mm) Width: 11.25" (285.75 mm) Depth: 9.75" (247.65 mm)	Height: 15.25" (387.35 mm) Width: 11.25" (285.75 mm) Depth: 10.5" (266.75 mm)	Height: 11.75" (298.5 mm) Width: 12.50" (317.5mm) Depth: 14.25" (362.0 mm)		

FEATURES REPRESENTED IN ALL OUR MODELS:

- Intel® Xeon® processor D-1518 4-Core, with optional eight and 16-Core expandability featuring the latest 14nm energy-efficient SoC
- Dual 10GbE fiber & copper expandability for highly efficient virtualization and intensive data transmission
- LCD for real-time information and easier system management
- Smart-Cooling Fan detects CPU and hard drive temperatures to control fan speeds dynamically for quieter operation
- Comes with two hardware encryption keys
- Top-of-the-line hardware for maximum reliability and performance
- Hardware accelerated AES-256-bit encryption
- Supports four DDR4 memory modules for a maximum of 128GB RAM
- Built-in M.2 SATA 6GB/s slot provides the greatest flexibility in tiered storage configuration with native high speeds, empowering SSD caching
- Centralized management solution for networked computing devices
- Supports centralized storage, backup, sharing, and disaster recovery

- High-speed duplicate and transfer between local and remote servers with Rsync
- Instant Secure Erase (ISE)
- USB blocker for enhanced security
- Optional extended 5-year warranty (3-year standard warranty)

ADDITIONAL FEATURES ON OUR NVMe MODEL:

- 100GbE and 200GbE fiber connectivity for highly efficient virtualization and intensive data transmission
- All-Flash NVMe for maximum performance and IOPS
- Powered by CX-Linux ZFS all-in-one storage platform for software-defined disks and volume management
- IPMI Support for Intelligent Platform Management Interface v.2.0 IPMI 2.0 with virtual media over LAN and KVM over-LAN support
- Accelerated AES-256 Bit encryption powered by Intel® AES-NI
- Built-in M.2 SATA 6GB/s slot for ultra-high-speed performance and ZFS tiered caching
- LED Indicators for Status/Power, Disks status, USB, LAN



CIPHERTEX[®] data security



At Ciphertex, we strive to build trust and confidence in our customers by offering reliable, scalable, and user-friendly solutions that ensure their data's confidentiality, integrity, and availability.



3-years Included

WHY CIPHERTEX?

We develop and manufacture the most durable portable data storage systems available. Our products mechanical design is military environmental test lab certified and ISO 9001:2015 certified. We implement NIST, FIPS 140-2 level 3/140-3 to meet DoD requirement for mechanical design and hardware encryption key (Ciphertex Protect[®]) to protect data in transit and at rest. We also customize our products to fit our customer's needs. All our products are developed and manufactured in the USA. Customer satisfaction and data security are our #1 priority.

Organizations Worldwide Trust Their Data to Ciphertex



9301 Jordan Avenue, #105A • Chatsworth, CA 91311 • 877.977.8878 • 818.773.8989 • www.ciphertex.com

Ciphertex[®] Data Security is Intellectual Property Licensing under Legal and Intellectual Property Law.

Ciphertex[®] Data Security is a registered trademark of Ciphertex[®] Data Security, Ciphertex[®] is registered in many jurisdictions worldwide.